

HS SERIES INSTALLATION INSTRUCTIONS

BY

RadonAway™

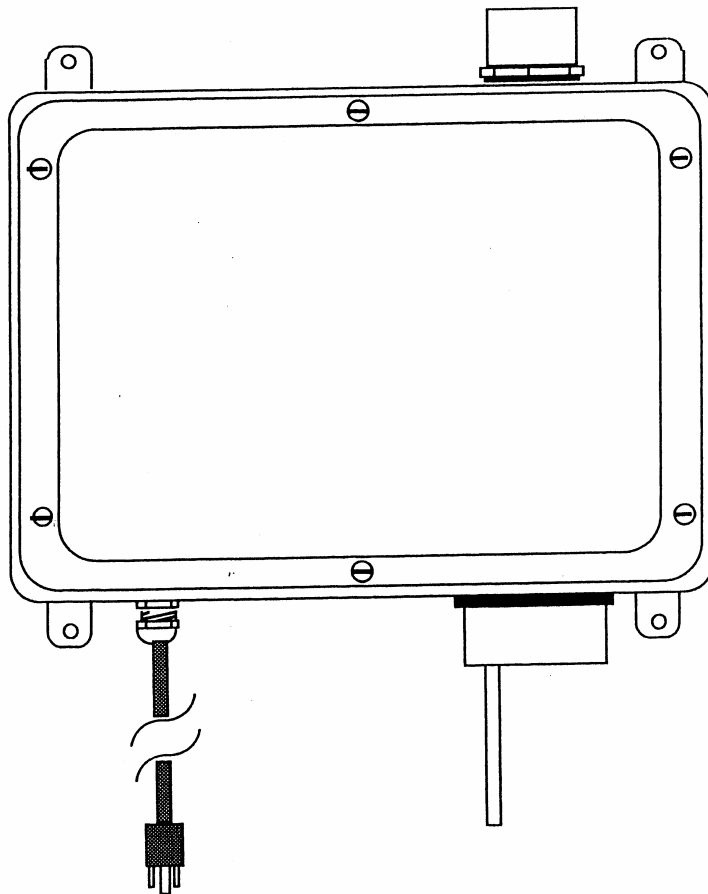
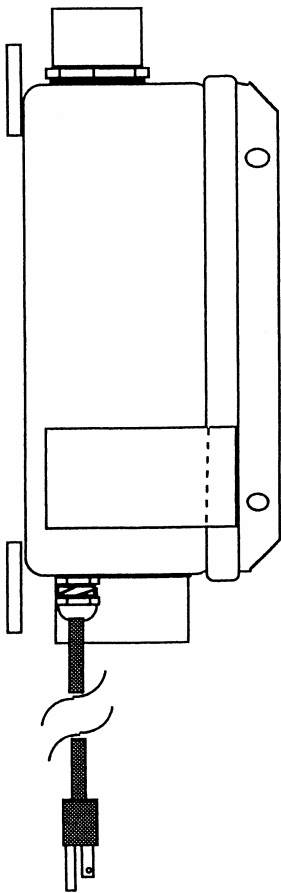

RadonAway, Inc. Ward Hill, MA.

P/N IN007 Rev F



RadonAway Ward Hill, MA.

HS Series Fan Installation Instructions

Please Read and Save These Instructions.

DO NOT CONNECT POWER SUPPLY UNTIL FAN IS COMPLETELY INSTALLED. MAKE SURE ELECTRICAL SERVICE TO FAN IS LOCKED IN "OFF" POSITION. DISCONNECT POWER BEFORE SERVICING FAN.

1. **WARNING!** Do not use fan in hazardous environments where fan electrical system could provide ignition to combustible or flammable materials.
2. **WARNING!** Do not use fan to pump explosive or corrosive gases.
3. **WARNING!** Check voltage at the fan to insure it corresponds with nameplate.
4. **WARNING!** Normal operation of this device may affect the combustion airflow needed for safe operation of fuel burning equipment. Check for possible backdraft conditions on all combustion devices after installation.
5. **NOTICE!** There are no user serviceable parts located inside the fan unit. **Do NOT attempt to open.** Return unit to the factory for service.
6. All wiring must be performed in accordance with the National Fire Protection Association's (NFPA) "National Electrical Code, Standard #70"-current edition for all commercial and industrial work, and state and local building codes. All wiring must be performed by a qualified and licensed electrician..
7. **WARNING!** In the event that the fan is immersed in water, return unit to factory for service before operating.
8. **WARNING!** Do not twist or torque fan inlet or outlet piping as Leakage may result.
9. **WARNING!** Do not leave fan unit installed on system piping without electrical power for more than 48 hours. Fan failure could result from this non-operational storage.

INSTALLATION INSTRUCTIONS (Rev F)
for DynaVac High Suction Series
HS2000 p/n 23004-1
HS3000 p/n 23004-2
HS5000 p/n 23004-3

1.0 SYSTEM DESIGN CONSIDERATIONS

1.1 INTRODUCTION

The DynaVac is intended for use by trained, professional Radon mitigators. The purpose of this instruction is to provide additional guidance for the most effective use of the DynaVac. This instruction should be considered as a supplement to EPA standard practices, state and local building codes and state regulations. In the event of a conflict, those codes, practices and regulations take precedence over this instruction.

1.2 ENVIRONMENTALS

The DynaVac is designed to perform year-round in all but the harshest climates without additional concern for temperature or weather. For installations in an area of severe cold weather, please contact RadonAway for assistance. When not in operation, the DynaVac should be stored in an area where the temperature is never less than 32 degrees F. or more than 100 degrees F. The DynaVac is thermally protected such that it will shut off when the internal temperature is above 104 degrees F. Thus if the DynaVac is idle in an area where the ambient temperature exceeds this shut off, it will not restart until the internal temperature falls below 104 degrees F.

1.3 ACOUSTICS

The DynaVac, when installed properly, operates with little or no noticeable noise to the building occupants. There are, however, some considerations to be taken into account in the system design and installation. When installing the DynaVac above sleeping areas, select a location for mounting which is as far away as possible from those areas. Avoid mounting near doors, fold-down stairs or other uninsulated structures which may transmit sound. Insure a solid mounting for the DynaVac to avoid structure-borne vibration or noise.

The velocity of the outgoing air must also be considered in the overall system design. With small diameter piping, the "rushing" sound of the outlet air can be disturbing. The system design should incorporate a means to slow and quiet the outlet air. The use of the RadonAway Exhaust Muffler, p/n 24001, is strongly recommended.

1.4 GROUND WATER

Under no circumstances should water be allowed to be drawn into the inlet of the DynaVac as this may result in damage to the unit. The DynaVac should be mounted at least 5 feet above the slab penetration to minimize the risk of filling the DynaVac with water in installations with occasional high water tables.

In the event that a temporary high water table results in water at or above slab level, water will be drawn into the riser pipes thus blocking air flow to the DynaVac. The lack of cooling air will result in the DynaVac cycling on and off as the internal temperature rises above the thermal cutoff and falls upon shutoff. Should this condition arise, it is recommended that the DynaVac be disconnected until the water recedes allowing for return to normal operation.

1.5 CONDENSATION & DRAINAGE

(WARNING! : Failure to provide adequate drainage for condensation can result in system failure and damage the DynaVac).

Condensation is formed in the piping of a mitigation system when the air in the piping is chilled below its dew point. This can occur at points where the system piping goes through unheated space such as an attic, garage or outside. The system design must provide a means for water to drain back to a slab hole to remove the condensation.

The use of small diameter piping in a system increases the speed at which the air moves. The speed of the air can pull water uphill and at sufficient velocity it can actually move water vertically up the side walls of the pipe. This has the potential of creating a problem in the negative pressure (inlet) side piping. For DynaVac inlet piping, the following table provides the minimum recommended pipe diameters as well as minimum pitch under several system condition. Use this chart to size piping for a system.

Pipe Diam.	Minimum Rise per Foot of Run*		
	@ 25 CFM	@ 50 CFM	@ 100 CFM
4"	1/32 "	3/32 "	3/8 "
3"	1/8 "	3/8 "	1 1/2 "

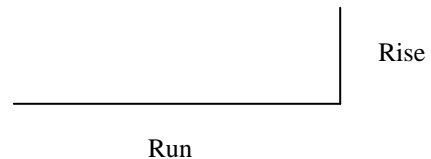

*Typical operational flow rates:

HS3000, or HS5000	20 - 40 CFM
HS2000	50 - 90 CFM

All exhaust piping should be 2" PVC.

1.6 "SYSTEM ON" INDICATOR

A properly designed system should incorporate a "System On" Indicator for affirmation of system operation. A Magnehelic pressure gauge is recommended for this purpose. The indicator should be mounted at least 5 feet above the slab penetration to minimize the risk of filling the gauge with water in installations with occasional high water tables.

1.7 SLAB COVERAGE

The DynaVac can provide coverage of well over 1000 sq. ft. per slab penetration. This will, of course, depend on the sub-slab aggregate in any particular installation and the diagnostic results. In general, sand and gravel are much looser aggregates than dirt and clay. Additional suction points can be added as required. It is recommended that a small pit (2 to 10 gallons in size) be created below the slab at each suction hole.

1.8 ELECTRICAL WIRING

The DynaVac plugs into a standard 120V outlet. All wiring must be performed in accordance with the National Fire Protection Association's (NFPA) "National Electrical Code, Standard #70"-current edition for all commercial and industrial work, and state and local building codes. All wiring must be performed by a qualified and licensed electrician.

1.8a ELECTRICAL BOX (optional)

The optional Electrical Box (p/n 20003) provides a weathertight box with switch for outdoor hardwire connection. All wiring must be performed in accordance with the National Fire Protection Association's (NFPA) "National Electrical Code, Standard #70"-current edition for all commercial and industrial work, and state and local building codes. All wiring must be performed by a qualified and licensed electrician. Outdoor installations require the use of a U.L. listed watertight conduit.

1.9 SPEED CONTROLS

Electronic speed controls can **NOT** be used on HS series units.

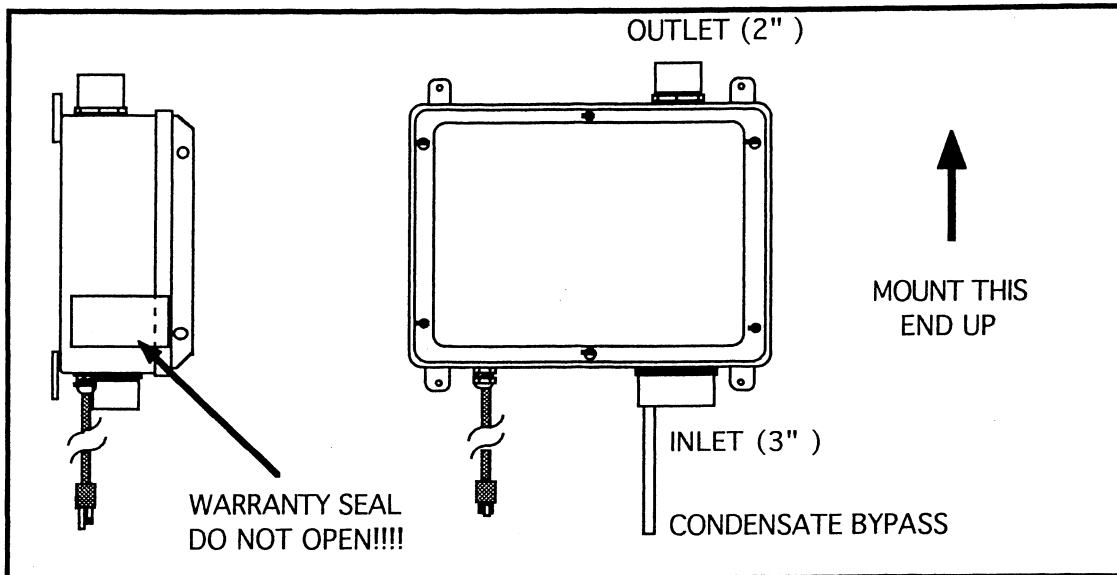

2.0 INSTALLATION

2.1 MOUNTING

Mount the DynaVac to the wall studs, or similar structure, in the selected location with (4) 1/4" x 1 1/2" lag screws (not provided). Insure the DynaVac is both plumb and level.

2.2 DUCTING CONNECTIONS

Make final ducting connection to DynaVac with flexible couplings. Insure all connections are tight. Do not twist or torque inlet and outlet piping on DynaVac or leaks may result.

2.3 VENT MUFLER INSTALLATION

Install the muffler assembly in the selected location in the outlet ducting. Solvent weld all connections. The muffler is normally installed above the roofline at the end of the vent pipe.

2.5 OPERATION CHECKS

___ Make final operation checks by verifying all connections are tight and leak-free.

___ Insure the DynaVac and all ducting is secure and vibration-free.

___ Verify system vacuum pressure with Magnehelic. Insure vacuum pressure is less than the maximum recommended as shown below:

DynaVac	HS2000	14" WC
DynaVac	HS3000	21" WC
DynaVac	HS5000	40" WC

(Above are based on sea-level operation, at higher altitudes reduce above by about 4% per 1000 Feet.)

If these are exceeded, increase number of suction points.

___ Verify Radon levels by testing to EPA protocol.

Addendum

PRODUCT SPECIFICATIONS

Model	Maximum Static Suction	Typical CFM vs Static Suction WC (Recommended Operating Range)						Power* Watts @ 115 VAC
		0"	10"	15"	20"	25"	35"	
HS2000	18"	110	72	40	-	-	-	150-270
HS3000	27"	40	33	30	23	18	-	105-195
HS5000	50"	53	47	42	38	34	24	180-320

*Power consumption varies with actual load conditions

Inlet: 3.0" PVC

Outlet: 2.0" PVC

Mounting: Brackets for vertical mount

Weight: Approximately 18 lbs.

Size: Approximately 15"W x 13"H x 8"D

Minimum recommended inlet ducting (greater diameter may always be used):

HS3000, HS5000 --- 2.0" PVC Pipe

HS2000 --- Main feeder line of 3.0" or greater PVC Pipe

Branch lines (if 3 or more) may be 2.0" PVC Pipe

Outlet ducting: 2.0" PVC

Storage temperature range: 32 - 100 degrees F.

Thermally protected

Locked rotor protection

Internal Condensate Bypass

IMPORTANT INSTRUCTIONS TO INSTALLER

Inspect the HS Series Fan for shipping damage within 15 days of receipt. Notify **RadonAway of any damages immediately**. Radonaway is not responsible for damages incurred during shipping. However, for your benefit, Radonaway does insure shipments.

There are no user serviceable parts inside the fan. **Do not attempt to open.** Return unit to factory for service.

Install the HS Series Fan in accordance with all EPA standard practices, and state and local building codes and state regulations.

WARRANTY

Subject to any applicable consumer protection legislation, RadonAway warrants that the HS Series Fan (the "Fan") will be free from defects in materials and workmanship for a period of one (1) year from the date of manufacture (the "Warranty Term"). Outside the Continental United States and Canada the Warranty Term is one (1) year from the date of manufacture.

RadonAway will replace any Fan which fails due to defects in materials or workmanship. The Fan must be returned (at owner's cost) to the RadonAway factory. Proof of purchase must be supplied upon request for service under this Warranty.

This Warranty is contingent on installation of the Fan in accordance with the instructions provided. This Warranty does not apply where any repairs or alterations have been made or attempted by others, or if the unit has been abused or misused. Warranty does not include damage in shipment unless the damage is due to the negligence of RadonAway.

RadonAway is not responsible for installation, removal or delivery costs associated with this Warranty.

EXCEPT AS STATED ABOVE, THE HS SERIES FANS ARE PROVIDED WITHOUT WARRANTY OF ANY KIND, EITHER EXPRESS OR IMPLIED, INCLUDING, WITHOUT LIMITATION, IMPLIED WARRANTIES OF MERCHANTABILITY AND FITNESS FOR A PARTICULAR PURPOSE.

IN NO EVENT SHALL RADONAWAY BE LIABLE FOR ANY DIRECT, INDIRECT, SPECIAL, INCIDENTAL, OR CONSEQUENTIAL DAMAGES ARISING OUT OF, OR RELATING TO, THE FAN OR THE PERFORMANCE THEREOF. RADONAWAY'S AGGREGATE LIABILITY HEREUNDER SHALL NOT IN ANY EVENT EXCEED THE AMOUNT OF THE PURCHASE PRICE OF SAID PRODUCT. THE SOLE AND EXCLUSIVE REMEDY UNDER THIS WARRANTY SHALL BE THE REPAIR OR REPLACEMENT OF THE PRODUCT, TO THE EXTENT THE SAME DOES NOT MEET WITH RADONAWAY'S WARRANTY AS PROVIDED ABOVE.

For service under this Warranty, contact RadonAway for a Return Material Authorization (RMA) number and shipping information. No returns can be accepted without an RMA. If factory return is required, the customer assumes all shipping cost to and from factory.

RadonAway
3 Saber Way
Ward Hill, MA 01835
TEL. (978) 521-3703
FAX (978) 521-3964

Record the following information for your records:

Serial No. _____
Purchase Date _____